

 **TOYOTA**
INDUSTRIAL EQUIPMENT

One Source
RENTALS • SALES • SERVICE





Brick, Block
& Pipe



Distribution



Factory



General
Manufacturing



General
Warehousing



Lumber



Paper



Retail

- Control Area Network (CAN-bus) communication
- Fully stamped steel side panels
- Moisture-resistant electric connectors
- High cooling capacity radiator with fan shroud

- Tilt cylinder boots
- Low-maintenance battery
- Large-capacity engine cooling fan
- 7" cyclone air cleaner with high positioned external air intake
- Plate-iron front fenders

- Anti-restart ignition key switch
- Stamped steel engine hood
- Fully sealed air intake system
- Self-adjusting brakes

- System of Active Stability™ (SAS)
- Operator Presence Sensing System (OPSS)

- Bolt-on overhead guard
- Key lowering interlock
- Electric horn

- Neutral start safety switch
- Asbestos-free components

- EPA/CARB-certified engine
- Toyota 4-cylinder, 2.2 liter, OHV gasoline engine (4Y-ECS)
- Toyota 3-cylinder, 1.8 liter, Tier 4 Final diesel engine (1ZS)
- Electronic fuel injection (gasoline only)
- UL "G" gasoline engine
- UL "D" diesel engine
- One-way automatic fork leveling
- Independent brake & inching pedals

- Integrated monitoring system - includes:
 - Digital hour meter display
 - Engine coolant temperature gauge
 - Fuel gauge (gasoline only)
 - Check engine light
 - Sedimentor warning light (diesel only)
 - Glow indicator light (diesel only)
 - Engine oil pressure warning light
 - Battery charge warning light
 - OPSS activation light
 - SAS/OPSS warning light

- Limited free-lift 2-stage mast (V)
- Adjustable headlights with guards
- Foot-activated parking brake
- Alternator with built-in regulator
- Transistorized ignition assembly
- Automatic transmission with oil cooler
- Full-floating powertrain
- Hydraulic valve lifters
- Integrated headlight & turn signal lever
- Electric shift control
- Speed control (technician programmable)

- Dash-mounted instrument display
- 11.8"-dia., two-spoke steering wheel
- Load-sensing hydrostatic power steering
- Heavy-duty non-slip rubber floor mat
- 12"-long dual operator assist grips

- Cowl-mounted hydraulic control levers with rubber boot covers
- Low, wide entry steps
- Low-profile front cowl
- Non-cinching seatbelt

- Dash-integrated amenity tray & oversized cup holder
- Vinyl 4-way adjustable full-suspension seat
- Slim profile, tilt steering column

- Easy-access no tools required floorboard
- Engine hood assist damper with lock device

- Air cleaner discharge valve
- Externally mounted hydraulic oil return filter

- Dash-mounted brake fluid level check
- Easy-lift engine hood with wide 75° opening

- Travel speed/acceleration control system
- Multifunction digital display with self-diagnostics, engine protection system, eco-mode & speed control (customer programmable)
- Hydraulic accumulator
- Intelli-Shift
- Orange seatbelt
- Rear assist grip with horn button
- Rustproof spec
- Mini-lever controls with ErgoShift
- Joystick controls with ErgoShift
- Swivel seat
- Synchronized steering
- High-mount rear combination lights
- LED front headlights
- LED rear combination lights

- Deluxe steel cab
- Standard steel cab
- 12-Volt power supply
- EZ Pedal (foot directional control)
- Plate fin radiator
- Radiator screen
- Fire extinguisher
- Front combination lights
- Steering wheel with knob
- Polished and tapered forks
- Integral & hang-on sidershifters
- Integral side shifting fork positioner
- Bottler's tilt
- LPG low-fuel warning light & alarm
- High-capacity 70-amp alternator (4Y-ECS models)
- Strobe lights
- Step-mounted toolbox with cover

- Back up alarms
- Cloth 4-way adjustable full-suspension seat
- Combination brake & inching pedal
- Pre-cleaner for air intake
- Rearview mirrors
- Wide tread tires
- UL "GS" gasoline model
- UL "DS" diesel model
- 4Y-ECS high-power engine
- Fuel system configurations with swing-out tank bracket & one-touch latch system
 - UL-LP
 - UL-LPS
 - UL-LPG dual fuel
 - UL-CNG/G dual fuel
- Swing-down LPG tank bracket



One Source
 RENTALS • SALES • SERVICE

			FGU25				
Load Capacity	lb (kg)		4000 (1800)	4000 (1800)	6000 (2250)	6000 (2250)	
Power Type			Gasoline	Diesel	Gasoline	Diesel	
Operator Position			Seated Rider	Seated Rider	Seated Rider	Seated Rider	
Tire Type	Front / Rear		Pneumatic / Pneumatic	Pneumatic / Pneumatic	Pneumatic / Pneumatic	Pneumatic / Pneumatic	
Wheels (x = driven)	Front / Rear		2x / 2	2x / 2	2x / 2	2x / 2	
Maximum Fork Height (top of forks)	in (mm)		131.6 (3340)	131.5 (3340)	131.6 (3340)	131.5 (3340)	
Free-Lift (top of forks)	in (mm)		6.1 (155)	6.1 (155)	6.1 (155)	6.1 (155)	
Fork Size (T x W x L)	in (mm)		1.6 x 5 x 42 (40 x 125 x 1070)	1.6 x 5 x 42 (40 x 125 x 1070)	1.6 x 5 x 42 (40 x 125 x 1070)	1.6 x 5 x 42 (40 x 125 x 1070)	
Fork Spread Max. / Min. (outer edge to edge)	in (mm)		40 (1020) / 10 (250)	40 (1020) / 10 (250)	40 (1020) / 10 (250)	40 (1020) / 10 (250)	
Tilt Range (forward / backward)	deg		6 / 11	6 / 11	6 / 11	6 / 11	
Length to Fork Face	in (mm)		101.4 (2575)	101.4 (2575)	103.9 (2640)	103.9 (2640)	
Overall Width	in (mm)		45.3 (1150)	45.3 (1150)	45.3 (1150)	45.3 (1150)	
Mast Lowered Height	in (mm)		84.5 (2145)	84.5 (2145)	84.5 (2145)	84.5 (2145)	
Mast Extended Height (top of load backrest)	in (mm)		179.6 (4560)	179.6 (4560)	179.6 (4560)	179.6 (4560)	
Overhead Guard Height	in (mm)		83.1 (2110)	83.1 (2110)	83.1 (2110)	83.1 (2110)	
Turning Radius (inside / outside)	in (mm)		5.91 (150) / 84.7 (2150)	5.91 (150) / 84.7 (2150)	5.91 (150) / 87.5 (2220)	5.91 (150) / 87.5 (2220)	
Load Distance ¹	in (mm)		18.5 (470)	18.5 (470)	18.5 (470)	18.5 (470)	
Rear Overhang	in (mm)		17.9 (455)	17.9 (455)	20.5 (520)	20.5 (520)	
Basic Right-Angle Stacking Aisle Width ²	in (mm)		103.2 (2620)	103.2 (2620)	105.9 (2690)	105.9 (2690)	
Speeds ³	Maximum Travel (forward / reverse)	Full Load	mph (km/h)	10.9 (17.5) / 10.9 (17.5)	11.8 (19.0) / 11.8 (19.0)	10.9 (17.5) / 10.9 (17.5)	11.8 (19.0) / 11.8 (19.0)
		No Load	mph (km/h)	11.2 (18.0) / 11.2 (18.0)	12.1 (19.5) / 12.1 (19.5)	11.2 (18.0) / 11.2 (18.0)	12.1 (19.5) / 12.1 (19.5)
	Lifting	Full Load	fpm (mm/sec)	118 (600)	121 (615)	118 (600)	121 (615)
		No Load	fpm (mm/sec)	128 (640)	129 (655)	126 (640)	129 (655)
	Lowering	Full Load	fpm (mm/sec)	98 (500)	98 (500)	98 (500)	98 (500)
		No Load	fpm (mm/sec)	98 (500)	98 (500)	98 (500)	98 (500)
Drawbar Pull	Maximum	Full Load	lb (kg)	4250 (1930)	4250 (1930)	4250 (1930)	4250 (1930)
	No Load	lb (kg)	2020 (920)	2040 (930)	1910 (870)	1930 (880)	
Gradeability	1 mph (1.5 km/h) ³	Full Load	%	37	34	31	29
		No Load	%	41	39	34	33
	Maximum ³	No Load	%	23	23	20	20
Total Weight	lb (kg)		7080 (3210)	7230 (3290)	7840 (3560)	7980 (3630)	
Weight Distribution	Full Load (front / rear)	lb (kg)	9750 (4800) / 1330 (610)	9810 (4830) / 1420 (680)	11280 (5330) / 1580 (730)	11320 (5350) / 1670 (780)	
	No Load (front / rear)	lb (kg)	3130 (1420) / 3950 (1790)	3180 (1450) / 4050 (1840)	2980 (1350) / 4860 (2210)	3040 (1380) / 4950 (2250)	
Tires	Number (front / rear)		2 / 2	2 / 2	2 / 2	2 / 2	
	Front	Size	7.00-12-12PR (1)	7.00-12-12PR (1)	7.00-12-12PR (1)	7.00-12-12PR (1)	
	Rear	Size	8.00-9-10PR (1)	8.00-9-10PR (1)	8.00-9-10PR (1)	8.00-9-10PR (1)	
Wheelbase	in (mm)		65 (1650)	65 (1650)	65 (1650)	65 (1650)	
Tread Width (front / rear)	in (mm)		37.8 (980) / 38.0 (985)	37.8 (980) / 38.0 (985)	37.8 (980) / 38.0 (985)	37.8 (980) / 38.0 (985)	
Underclearance (full load)	Minimum with Load	in (mm)	3.7 (95)	3.7 (95)	3.7 (95)	3.7 (95)	
	Center of Wheelbase	in (mm)	5.5 (140)	5.5 (140)	5.5 (140)	5.5 (140)	
Brake	Service (foot) / Parking		Hydraulic / Mechanical	Hydraulic / Mechanical	Hydraulic / Mechanical	Hydraulic / Mechanical	
Battery (5-hour rating)	V / Ah		12 / 48	12 / 52	12 / 48	12 / 52	
	Make / Model		TOYOTA / 4Y - ECS	TOYOTA / 1ZS	TOYOTA / 4Y - ECS	TOYOTA / 1ZS	
Internal Combustion Engine	Rated Horsepower @ rpm	SAE HP (kW)	51 @ 2570 Net (38 @ 2570)	55 @ 2200 Net (41 @ 2200)	51 @ 2570 Net (38 @ 2570)	55 @ 2200 Net (41 @ 2200)	
	Rated Torque @ rpm	SAE ft-lb (N-m)	118 @ 2100 Net (160 @ 2100)	148 @ 1600 Net (200 @ 1600)	118 @ 2100 Net (160 @ 2100)	148 @ 1800 Net (200 @ 1600)	
	Number of Cylinders		4	3	4	3	
	Piston Displacement cu in (cc)		138 (2237)	110 (1795)	138 (2237)	110 (1795)	
	Fuel Tank Capacity US gal (liter)		15.9	15.9	15.9	15.9	
Transmission	Type		Powershift	Powershift	Powershift	Powershift	
	Speeds (forward / reverse)		1 / 1	1 / 1	1 / 1	1 / 1	
Auxiliary Hydraulic Function Specifications (for attachments) ⁴	Max. Operating Pressure	psi (kg/cm ²)	2275 (160)	2275 (160)	2275 (160)	2275 (160)	
	Max. Flow Rate	gpm	20	19	20	19	

1 Load distance at centerline of front axle to front face of forks.

2 Basic right-angle stacking aisle width, add load length & clearance

3 Computed values. Performance of LPG fuel system may be less than that of standard model shown.

4 Values taken at Hydraulic Control Valve. Does not take in to consideration losses through mast plumbing (hosing, fittings, QDs, etc.)

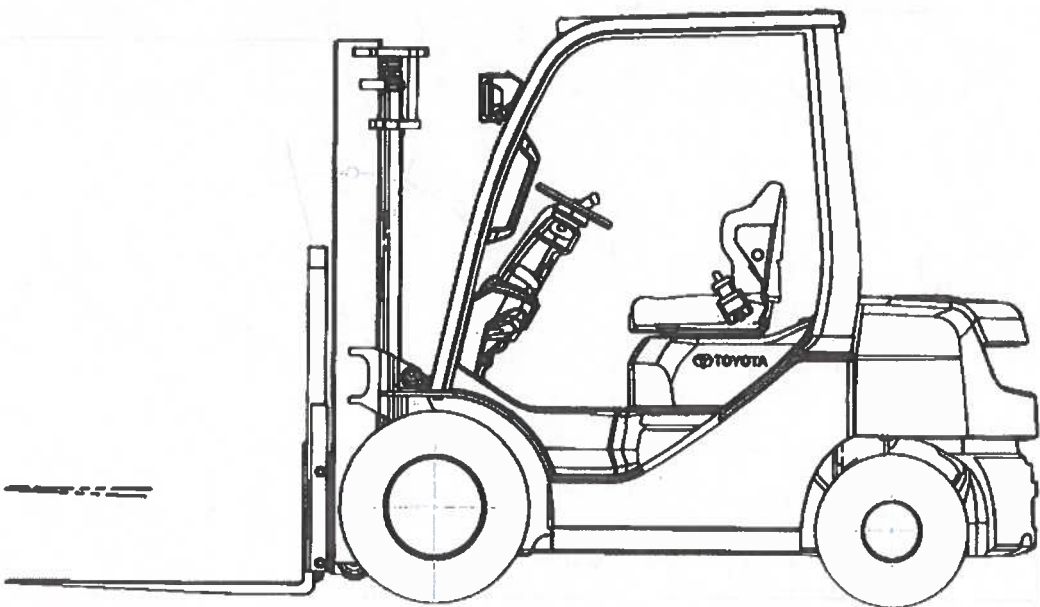
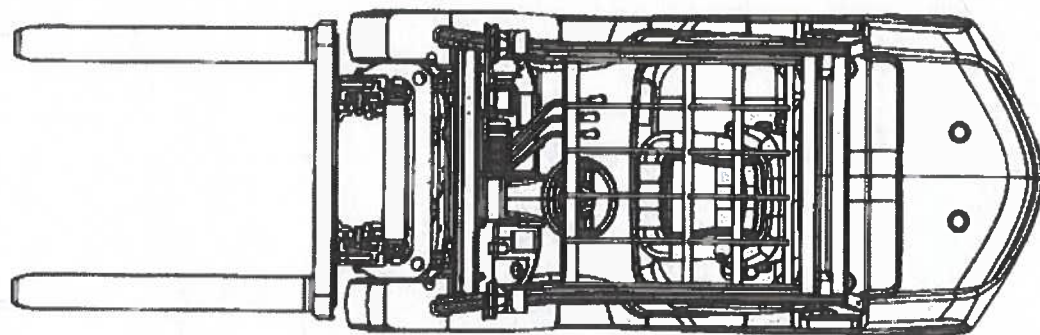

Wide Visible (V)	80 (2040)	58.9 (1495)	104.7 (2680)	128.3 (3280)	8.1 (155)	8.1 (155)	6/11	4000 (1800)	4000 (1800)	6/11	4000 (1800)
	119.5 (3040)	78.5 (1995)	144.1 (3660)	187.7 (4260)	8.1 (155)	8.1 (155)	6/11	4000 (1800)	4000 (1800)	6/11	4000 (1800)
	131.5 (3340)	84.5 (2145)	155.9 (3980)	179.5 (4580)	8.1 (155)	8.1 (155)	6/11	4000 (1800)	4000 (1800)	6/11	4000 (1800)
	139 (3540)	88.4 (2245)	183.8 (4180)	187.4 (4780)	6.1 (155)	6.1 (155)	6/11	4000 (1800)	4000 (1800)	6/11	4000 (1800)
	147 (3740)	94.7 (2405)	171.7 (4380)	195.3 (4980)	8.1 (155)	8.1 (155)	6/11	4000 (1800)	4000 (1800)	6/11	4000 (1800)
Full Free-Lift 2-Stage (FV)	159 (4040)	102.2 (2595)	183.5 (4660)	207.1 (5260)	8.1 (155)	8.1 (155)	6/11	4000 (1800)	4000 (1800)	6/11	4000 (1800)
	119.5 (3040)	78.5 (1995)	143.5 (3845)	187.7 (4280)	55.1 (1400)	30.5 (775)	6/11	4000 (1800)	4000 (1800)	6/11	4000 (1800)
	131.5 (3340)	84.5 (2145)	151.4 (3845)	179.5 (4580)	61 (1550)	36.4 (925)	6/11	4000 (1800)	4000 (1800)	6/11	4000 (1800)
Full Free-Lift 3-Stage (FSV)	139 (3540)	88.4 (2245)	163.2 (4145)	187.4 (4780)	85 (1650)	40.4 (1025)	6/11	4000 (1800)	4000 (1800)	6/11	4000 (1800)
	159 (4040)	74.6 (1895)	181.5 (4610)	206.7 (5250)	52.4 (1330)	26.6 (675)	6/6	4000 (1800)	4000 (1800)	6/6	4000 (1800)
	170.5 (4340)	78.5 (1995)	193.3 (4910)	218.5 (5550)	56.3 (1430)	30.5 (775)	6/6	4000 (1800)	4000 (1800)	6/6	4000 (1800)
	189 (4800)	84.5 (2145)	211.4 (5370)	238.8 (6010)	62.2 (1580)	36.4 (915)	6/6	3900 (1750)	4000 (1800)	6/6	4000 (1800)
	198 (5040)	88.4 (2245)	220.9 (5610)	248.1 (6250)	66.1 (1680)	40.4 (1015)	6/6	3550 (1800)	4000 (1800)	6/6	4000 (1800)
	218 (5540)	94.7 (2405)	240.6 (6110)	265.7 (6750)	72.4 (1840)	46.7 (1185)	6/6	2800 (1250)	3500 (1600)	6/6	3750 (1700)
	237.5 (6040)	102.2 (2595)	260.2 (6610)	285.4 (7250)	79.9 (2030)	54.2 (1375)	6/6	2000 (900)	2550 (1150)	6/6	3300 (1500)
257.5 (6540)	112 (2845)	279.9 (7110)	305.1 (7750)	89.8 (2280)	64 (1825)	-	-	-	6/6	3200 (1450)	
277 (7040)	121.9 (3095)	299.6 (7610)	324.8 (8250)	89.6 (2530)	73.9 (1875)	-	-	-	6/6	2800 (1200)	

8FOUR25											
Wide Visible (V)	80 (2040)	58.9 (1495)	104.7 (2680)	128.3 (3280)	8.1 (155)	8.1 (155)	6/11	5000 (2250)	5000 (2250)	6/11	5000 (2250)
	119.5 (3040)	78.5 (1995)	144.1 (3660)	187.7 (4260)	8.1 (155)	8.1 (155)	6/11	6000 (2250)	5000 (2250)	6/11	5000 (2250)
	131.5 (3340)	84.5 (2145)	155.9 (3980)	179.5 (4580)	6.1 (155)	6.1 (155)	6/11	5000 (2250)	5000 (2250)	6/11	5000 (2250)
	139 (3540)	88.4 (2245)	183.8 (4180)	187.4 (4780)	8.1 (155)	6.1 (155)	6/11	5000 (2250)	6000 (2250)	6/11	5000 (2250)
	147 (3740)	94.7 (2405)	171.7 (4380)	195.3 (4980)	8.1 (155)	8.1 (155)	6/11	5000 (2250)	5000 (2250)	6/11	5000 (2250)
Full Free-Lift 2-Stage (FV)	159 (4040)	102.2 (2595)	183.5 (4660)	207.1 (5260)	6.1 (155)	6.1 (155)	6/11	5000 (2250)	5000 (2250)	6/11	5000 (2250)
	119.5 (3040)	78.5 (1995)	143.5 (3845)	187.7 (4280)	55.1 (1400)	30.5 (775)	6/11	5000 (2250)	5000 (2250)	6/11	5000 (2250)
	131.5 (3340)	84.5 (2145)	151.4 (3845)	179.5 (4580)	61 (1550)	36.4 (925)	6/11	5000 (2250)	6000 (2250)	6/11	5000 (2250)
Full Free-Lift 3-Stage (FSV)	139 (3540)	88.4 (2245)	163.2 (4145)	187.4 (4780)	85 (1650)	40.4 (1025)	6/11	5000 (2250)	5000 (2250)	6/11	5000 (2250)
	159 (4040)	74.6 (1895)	181.5 (4610)	206.7 (5250)	52.4 (1330)	26.6 (675)	6/6	5000 (2250)	5000 (2250)	6/6	5000 (2250)
	170.5 (4340)	78.5 (1995)	193.3 (4910)	218.5 (5550)	56.3 (1430)	30.5 (775)	6/6	5000 (2250)	6000 (2250)	6/6	5000 (2250)
	189 (4800)	84.5 (2145)	211.4 (5370)	236.6 (6010)	62.2 (1580)	36.4 (915)	6/6	3850 (1800)	4850 (2200)	6/6	4850 (2250)
	198 (5040)	88.4 (2245)	220.9 (5610)	246.1 (6250)	66.1 (1680)	40.4 (1015)	6/6	3650 (1600)	4500 (2050)	6/6	4850 (2200)
	218 (5540)	94.7 (2405)	240.6 (6110)	265.7 (6750)	72.4 (1840)	46.7 (1185)	6/6	2850 (1300)	3850 (1750)	6/6	4500 (2050)
	237.5 (6040)	102.2 (2595)	260.2 (6610)	285.4 (7250)	79.9 (2030)	54.2 (1375)	6/6	2000 (900)	2550 (1150)	6/6	3500 (1800)
257.5 (6540)	112 (2845)	279.9 (7110)	305.1 (7750)	89.8 (2280)	64 (1825)	-	-	-	6/6	3200 (1450)	
277 (7040)	121.9 (3095)	299.6 (7610)	324.8 (8250)	89.6 (2530)	73.9 (1875)	-	-	-	6/6	2500 (1150)	
Full Free-Lift 4-Stage (FV)	240 (6100)	84.8 (2155)	283.4 (6690)	289.4 (7360)	81 (1550)	35 (895)	6/3	-*	3800 (1720)	6/3	-
	258 (6600)	90.7 (2305)	281.5 (7150)	307.6 (7810)	87 (1700)	41 (1046)	6/3	-*	-*	6/3	-

1 Height of standard load backrest is 48" (1220 mm)
 * Please submit a TSOA for capacity.
 Wide tread standard for all models with a 189" & higher FSV mast. Wide tread deduct option 1 GOOD will configure back to narrow tread.
 High-lift SAS active mast functions not available on 80V mast.
 Must have Dual Drive Tires (FDDC) at extra cost for 258 FSV, 277 FSV

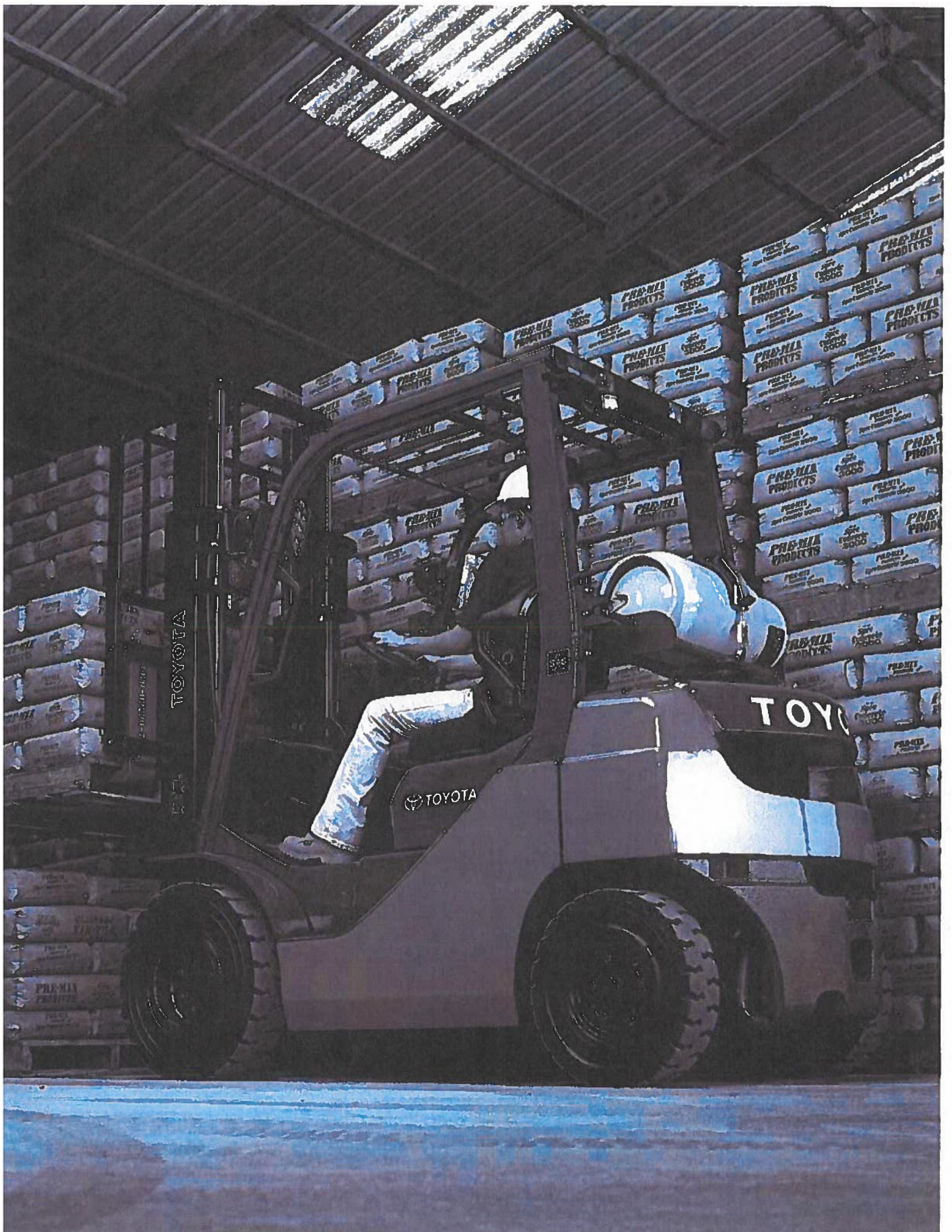

Some product features described herein are optional. Please consult your dealer for specifications.
Details of specifications and equipment are based on information available at time of printing and may
change without notice.



INDUSTRIAL EQUIPMENT